



# TECNOMAC

our technology, your taste

# TECNOMAC

our technology, your taste

BLAST CHILLERS  
2021

# TECNOMAC, TECHNOLOGY AND PERFORMANCE

Innovation and development, since ever, go with Castel MAC's history



Since 1963, we build retarder-prover chambers, conservation cabinets and blast chillers, designed to facilitate the job of those selecting our machines. From engineering to development, from the choice of materials to the assembly process, all the production cycle of Tecnomac machines is made in Italy, with all the meticulousness that characterizes our Company.

We aim at a continued technological innovation, to build innovative machines, highly performing and environmentally friendly, being the full customer satisfaction our main target.

The experience we matured during the years allows us to accomplish the most advanced technology in refrigeration and retarder-proving, to build reliable and user-friendly machines for the bakery, pastry, ice-

cream sectors, and food preparation in general.

Our machines' design embraces the precious principles of ergonomic and user-friendliness, and the safety of long-lasting components. We test our machines scrupulously, even in extreme conditions, to grant superior durability, reliability and safety. Since 1995 we are, among the rest, ISO 9001 certified.

Our products are precious allies for every kitchen and laboratory, by optimising each production process to achieve a more modern and efficient activity.



# BLAST CHILLERS

## The power of cold

The blast chilling process reached by using high-performances and technologically advanced blast chillers is the best method to prolong food and ingredients shelf-life, always granting freshness and fragrancy. The use of latest-generation blast chillers increases gastronomy, pastry and bakery activities productivity and efficiency, simplifying complex preparations stages and allowing to use a larger ingredients selection. Furthermore, this appliance is an essential instrument to complete ice-cream production cycle. Tecnomac blast chillers manages chilling/freezing phases in full

autonomy, with the possibility to program different times and temperatures.

Tecnomac proposes **Blast chillers for chilling and freezing cycles** from +90° to +3° and from +90° to -18°

### APPLICATIONS



BAKERY



PASTRY



GASTRONOMY



ICE CREAM

## BLAST CHILLERS

# Food safety

Cooked food cooled to room temperature loses all its best qualities. Tecnomac blast chiller lowers freshly cooked food core temperature down to +3°C or -18°C.

This process speed is essential, because it allows to minimize the bacteria proliferation that acts when food temperature range is +65°C/+10°C.

The final result is the quality, colour and fragrance optimal conservation and the total food safety.

# Work optimization

All chilled and frozen food is stored for longer and in better conditions.

This is an important gain for the user, who can plan the production, organizes more preparations in advance and manages a higher quantity of meals and semi-finished products.

The food quality is always granted, avoiding to repeat the same preparations every day.



## BLAST CHILLERS

# Saving is the keyword

Frozen food shelf-life extension, preserving all its quality and organoleptic characteristics, allows strategical and seasonal ingredient purchases: lower price, best taste and quality. Food optimal management avoids its perishability, definitively eliminating wastes.

# Quality is granted

Blast chilling and shock freezing processes stop the evaporation of water food contain. This assures fragrancly, taste and flavour and a correct food hydration, also in long conservation periods. Furthermore, this appliance allows to enrich menus and meals choice, offering high quality products, also with not seasonal ingredients.

# CHILLTOUCH



## LATEST-GENERATION MULTIFUNCTION BLAST CHILLERS

ChillTouch is more than a simple blast chiller: a mix of technology and design, that links functionality and user-friendliness to power and optimal temperature control.

Chilling, freezing, thawing, conservation, ice cream function, low temperature cooking and proving. The precise active humidity control, the powerful ventilation and the temperature management grant excellent performances, allowing to preserve all food organoleptic characteristics. A customizable machine, with the possibility to create recipes and to select the language of use.



ALL THE  
FUNCTIONS YOU  
ARE LOOKING  
FOR, ONE ONLY  
MACHINE

- COMPACT DIMENSIONS
- CONTROL PANEL WITH 7" TOUCH SCREEN
- DFC PATENTED ALGORITHM, TO MINIMIZE ICE FORMATION ON PRODUCT SURFACE DURING CHILLING CYCLE
- OPTIONAL OZONE SANITIZATION
- USB DRIVE TO DOWNLOAD HACCP DATA AND UPDATE SOFTWARE
- CONIC SHAPE CORE PROBE FOR TEMPERATURE CONTROLLING



- STAINLESS STEEL CONSTRUCTION AND 70 MM POLYURETHANE INSULATION, WITHOUT CFC
- EASY TO CLEAN WITH DEEP-FORMED INTERNAL FLOOR AND EXTRACTIBLE RACKS

## AN OPTIMAL MANAGEMENT

Endless functions, easy to set, to create and to customize on the 7" touch control panel.

Full management of all the programs, chilling and freezing, proving, low temperature cooking and ice cream surface hardening, the touch control panel allows to control the Ozone sanitization, the drying function and the hot gas defrosting.

Furthermore, the synoptic visualisation shares the machine parameters set and offers the possibility to control the recent or old alarm list.

## THE CONTROL ON YOUR FINGERTIPS

All the functions you can think of, directly managed on your smartphone. The wi-fi system allows the machine complete remote control, for maximum convenience and with no app installation need.

## CHILLING

Five different cycles to select, to grant a delicate or more intensive blast chilling of the product. From +95°C, the product can reach in 90 minutes +3°C at the core, preserving all its organoleptic characteristics. Each chilling cycle ends with automatic product conservation at +2°C inside the chamber.

## FREEZING

Five freezing cycle pre-set, to satisfy any freezing exigencies. From +95°C, the product can reach in 4 hours -18°C at the core, fully respecting HACCP norms. The Run cycle is the continuous cycle to be manual stopped. At the end of each cycle, the automatic product conservation is set at -25°C inside the chamber.



## THAWING

Temperature control, fans speed adjustment and humidity management assure a rapid thawing process, preserving all the food quality.

## CONSERVATION

Food preservation at a constant temperature allows its optimal conservation, in order to manage in the best possible way all the production phases of elaborated meals. This very versatile cycle can be adapted also to regenerate products, then ready to be served.





## ICE CREAM FUNCTION

A timed cycle combines the meticulous temperature control and the fans speed, to obtain the correct ice cream pans surface hardening: an essential process for their proper display or conservation.

## RETARDER PROVING

The Tecnomac experience in advanced retarder prover machines has been introduced also in ChillTouch. The proving control in each single phase is granted by the temperature set, the active humidity control and the fans speed adjustment.

## LOW TEMPERATURE COOKING

A safe and healthy cooking is the main purpose. Low temperature cooking is an innovative technique that preserves the organoleptic food quality and all its flavour. This function can be manually set or programmed, to obtain customized cycles and recipes setting active humidity, temperature and ventilation.

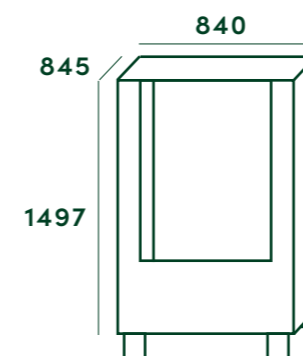

### CT 10.35

capacity	10 trays GN 1/1 or 600x400
+90°C > 3°C	35kg
+90°C > -18°C	25kg
dimensions	840 x 845 x 1497:1547 mm
voltage	400V / 3N / 50 Hz

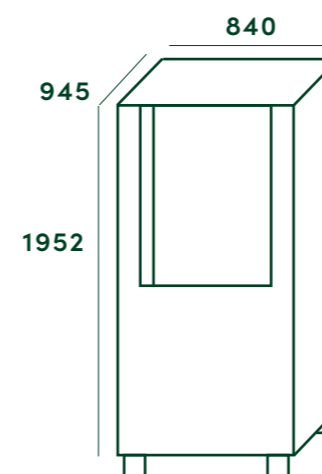

### CT 15.65

capacity	15 trays GN 1/1 or 600x400
+90°C > 3°C	65kg
+90°C > -18°C	50kg
dimensions	840 x 945 x 1952:2002 mm
voltage	400V / 3N / 50 Hz

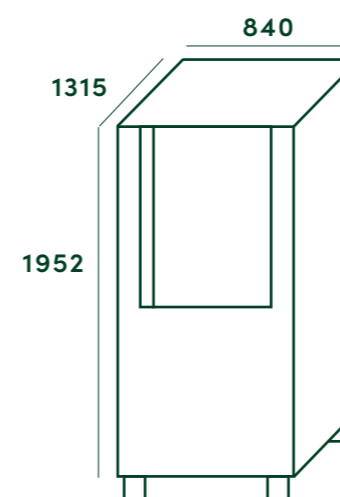

### CT 15-2.70

capacity	30 trays GN 1/1 or 600x400
+90°C > 3°C	70kg
+90°C > -18°C	55kg
dimensions	840 x 1315 x 1952:2002 mm
voltage	400V / 3N / 50 Hz

# EVENT



## POWERFUL AND VERSATILE BLAST CHILLERS

Chilling, freezing, thawing and ice cream function. eVent is a complete and efficient machine, that allows a correct and practical cooling management in every kitchen and laboratory. A simple and intuitive display to program different chilling and freezing cycles, memorising the most useful set. eVent is powerful and compact, and it allows to perfectly organize the meal preparations processes and to conserve the products.



**SIMPLICITY AND  
EFFICIENCY:  
THE ADVANCED  
BLAST CHILLER**



□ HIGH PERFORMANCE

□ CONIC SHAPE CORE PROBE FOR TEMPERATURE CONTROLLING

□ INTUITIVE ALPHANUMERIC DISPLAY

□ STAINLESS STEEL CONSTRUCTION AND 70 MM POLYURETHANE INSULATION, WITHOUT CFC

□ OPTIONAL OZONE SANITIZATION

□ EASY TO CLEAN WITH DEEP-FORMED INTERNAL FLOOR AND EXTRACTIBLE RACKS

□ USB DRIVE TO DOWNLOAD HACCP DATA AND UPDATE SOFTWARE

□ CONDENSATION COLLECTING PAN



## CHILLING

Four different cycles to select, to grant a delicate or more intensive blast chilling of the product. From +95°C, the product can reach in 90 minutes +3°C at the core, preserving all its organoleptic characteristics. Each chilling cycle ends with automatic product conservation at +2°C inside the chamber.

## FREEZING

Four freezing cycle pre-set, to satisfy any freezing exigencies. From +95°C, the product can reach in 4 hours -18°C at the core, fully respecting HACCP norms. The Run cycle is the continuous cycle to be manual stopped. At the end of each cycle, the automatic product conservation is set at -25°C inside the chamber.

## THAWING

A dedicated icon for a temporized thawing cycle through forced ventilation, that preserves the organoleptic characteristics of the products and their weight.

## ICE CREAM FUNCTION

A timed cycle combines the meticulous temperature control and the fans speed, to obtain the correct ice cream pans surface hardening: an essential process for their proper display or conservation.



## EVENT

### V 5.20

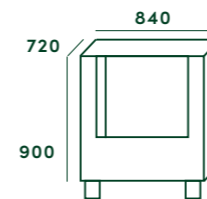

capacity	5 trays GN 1/1 or 600x400
+90°C > 3°C	20kg
+90°C > -18°C	12kg
dimensions	840 x 720 (770) x 900:930 mm
voltage	230V / 1N / 50 Hz

### V 10.35

capacity	10 trays GN 1/1 or 600x400
+90°C > 3°C	35kg
+90°C > -18°C	25kg
dimensions	840 x 780 (831) x 1498:1558 mm
voltage	400V / 3N / 50 Hz

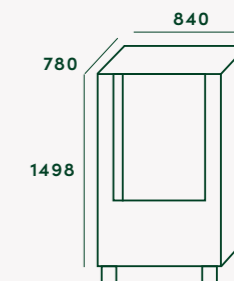

### V 15.40

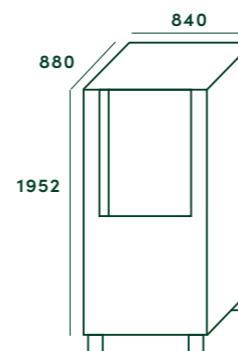

capacity	15 trays GN 1/1 or 600x400
+90°C > 3°C	40kg
+90°C > -18°C	30kg
dimensions	840 x 880 (930) x 1952:2002 mm
voltage	400V / 3N / 50 Hz

### V 15.65

capacity	15 trays GN 1/1 or 600x400
+90°C > 3°C	65kg
+90°C > -18°C	50kg
dimensions	840 x 880 (930) x 1952:2002 mm
voltage	400V / 3N / 50 Hz

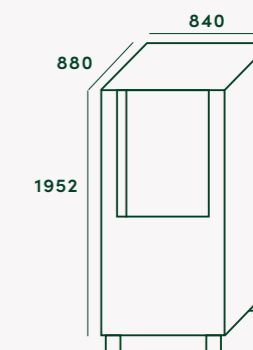

### V 15-2.70

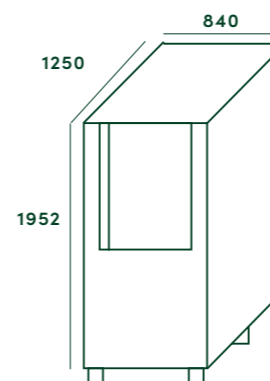

capacity	30 trays GN 1/1 or 600x400
+90°C > 3°C	70kg
+90°C > -18°C	55kg
dimensions	840 x 1250 (1300) x 1952:2002 mm
voltage	400V / 3N / 50 Hz

# BLACK KUBE



## SOLID AND PRACTICAL

Black Kube is the simplest solution to manage and organize the activities in the laboratory or in the kitchen of every single restaurant or pastry shop. Powerful, solid and reliable, Black Kube blast chillers series assure an optimal cooling management, from the chilling cycle to the freezing one, including also the perfect ice cream pans surface hardening.



BLACK KUBE

# THE ESSENTIAL CHILLING POWER



□ COMPACT DIMENSIONS

□ SOFT-TOUCH CONTROL PANEL

□ OPTIONAL OZONE SANITIZATION

□ OPTIONAL USB DRIVE FOR HACCP DATA DOWNLOAD

□ CONIC SHAPE CORE PROBE FOR TEMPERATURE CONTROLLING

□ OPTIONAL INTERNAL PASTRY RACK WITH VARIABLE PITCH 10MM

□ DEEP-FORMED INTERNAL FLOOR EASY TO CLEAN AND EXTRACTABLE TRAY SUPPORTS

□ ANTI-CORROSION FAN BLADES



## CHILLING

Two different blast chilling cycles, both to chill down the products from +95°C down to +3°C at the core, in one hour and half. Soft cycle is set for more delicate food or preparations, while Hard cycle must be used for more dense food and large products size. Each chilling cycle ends with automatic product conservation at +2°C inside the chamber.

## FREEZING

Thanks to the machine high efficiency and power, each freezing need will be satisfied. One only cycle to freeze products up to -18°C at the core, effective for dense, fat and big size food. At the end of each cycle, the automatic product conservation is set at -25°C inside the chamber.

# ICE CREAM FUNCTION

Useful cycle to complete the ice cream production, to assure its impeccable texture and creaminess for its display or conservation.

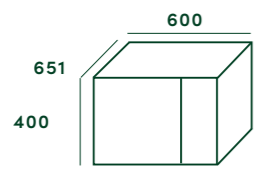

**BK3 2/3**  
 capacity 3 trays GN 2/3 (354x325)  
 trays pitch 70mm  
 output chilling 7kg  
 output freezing 5kg  
 dimensions 600x651x400 mm  
 voltage 230V / 1N / 50 Hz

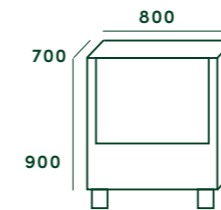

**BK+ 5-18**  
 capacity 5 trays GN 1/1 or 600x400  
 trays pitch 68mm  
 output chilling 18kg  
 output freezing 10kg  
 dimensions 800x700x900:930 mm  
 voltage 230V / 1N / 50 Hz

**BK3 1/1**  
 capacity 3 trays GN 1/1 (530x325)  
 trays pitch 70mm  
 output chilling 7kg  
 output freezing 5kg  
 dimensions 600x851x400 mm  
 voltage 230V / 1N / 50 Hz

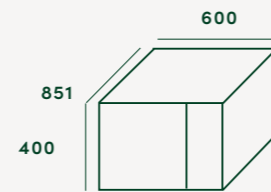

**BK+ 10-30**  
 capacity 10 trays GN 1/1 or 600x400  
 trays pitch 68mm  
 output chilling 32kg  
 output freezing 22kg  
 dimensions 800x700x1544:1599 mm  
 voltage 230V / 1N / 50 Hz

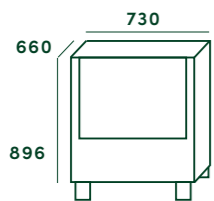
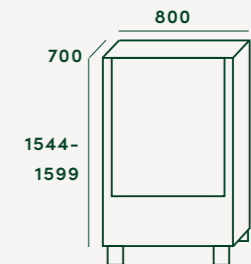

**BK 5 1/1**  
 capacity 5 trays GN 1/1 (530x325)  
 trays pitch 68mm  
 output chilling 14kg  
 output freezing 10kg  
 dimensions 730x660x896 mm  
 voltage 230V / 1N / 50 Hz

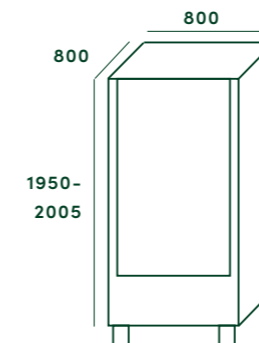

**BK+ 15-40**  
 capacity 15 trays GN 1/1 or 600x400  
 trays pitch 68mm  
 output chilling 40kg  
 output freezing 28kg  
 dimensions 800x800x1950:2005 mm  
 voltage 400V / 3N / 50 Hz

# CHILLTOUCH ROLL-IN



## POWER AND RELIABILITY

Chill-touch roll-in blast chillers combine Tecnomac power and construction technology and a very user-friendly machine, for trolleys aims. Ideal machines for artisanal or industrial laboratories, Chill-Touch roll-in machines are available in many different dimensions. The insulated floor with external ramp assures the maximal tightness and the best efficiency.



# FREEDOM OF MOVEMENT



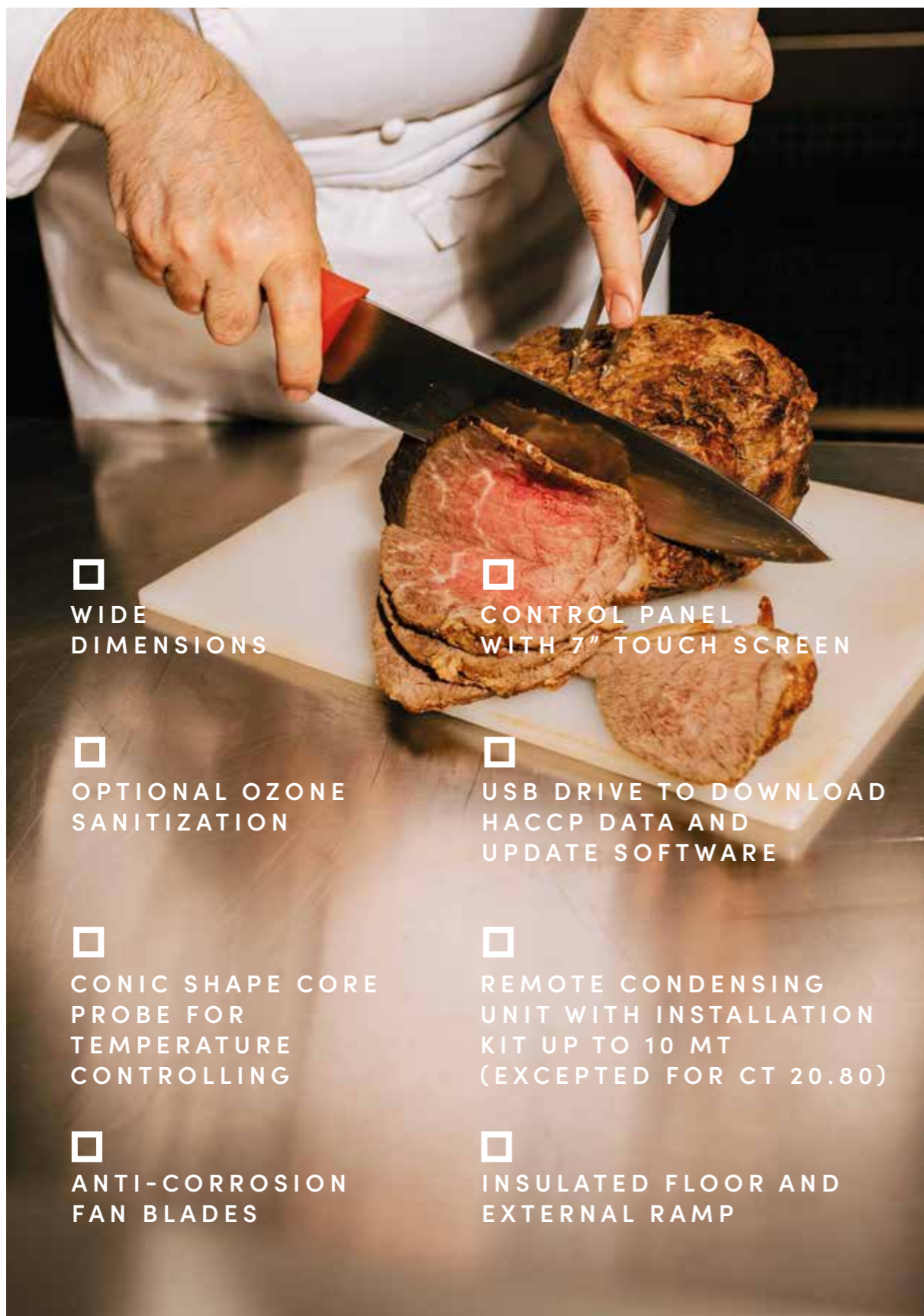

□ WIDE DIMENSIONS

□ CONTROL PANEL WITH 7" TOUCH SCREEN

□ OPTIONAL OZONE SANITIZATION

□ USB DRIVE TO DOWNLOAD HACCP DATA AND UPDATE SOFTWARE

□ CONIC SHAPE CORE PROBE FOR TEMPERATURE CONTROLLING

□ REMOTE CONDENSING UNIT WITH INSTALLATION KIT UP TO 10 MT (EXCEPTED FOR CT 20.80)

□ ANTI-CORROSION FAN BLADES

□ INSULATED FLOOR AND EXTERNAL RAMP

## CHILLING

Five different cycles to select, to grant a delicate or more intensive blast chilling of the product. From +95°C, the product can reach in 90 minutes +3°C at the core, preserving all its organoleptic characteristics. Each chilling cycle ends with automatic product conservation at +2°C inside the chamber.

## FREEZING

Five freezing cycle pre-set, to satisfy any freezing exigencies. From +95°C, the product can reach in 4 hours -18°C at the core, fully respecting HACCP norms. The Run cycle is the continuous cycle to be manual stopped. At the end of each cycle, the automatic product conservation is set at -25°C inside the chamber.

## THAWING

Dedicated icon for thawing cycle by time with controlled temperature and forced ventilation, very useful to preserve the products weight and organoleptic characteristics.

## CONSERVATION

Food preservation with constant temperature allows its best conservation, allowing the optimal management of elaborated meals preparations phases.



## ICE CREAM FUNCTION

A timed cycle combines the meticulous temperature control and the fans speed, to obtain the correct ice cream pans surface hardening: an essential process for their proper display or conservation.

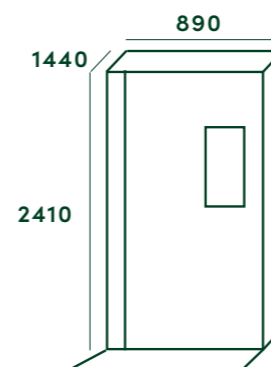

### CT 20-80 | CT 20-80 RE

<b>capacity</b>	1 trolley GN 1/1 or 600x400 1 trolley GN 2/1 or 800x600
<b>max dimensions trolley</b>	680x860x1860 mm
<b>output chilling</b>	80kg
<b>output freezing</b>	65kg
<b>dimensions</b>	890x1440x2410 mm
<b>voltage</b>	400V / 3N / 50 Hz
<b>construction</b>	monocoque version disassembled panels on request

### CT 20-110 RE

<b>capacity</b>	1 trolley GN 1/1 or 600x400 1 trolley GN 2/1 or 800x600
<b>max dimensions trolley</b>	680x860x1860 mm
<b>output chilling</b>	110kg
<b>output freezing</b>	95kg
<b>dimensions</b>	890x1440x2410 mm
<b>voltage</b>	400V / 3N / 50 Hz
<b>construction</b>	monocoque version disassembled panels on request

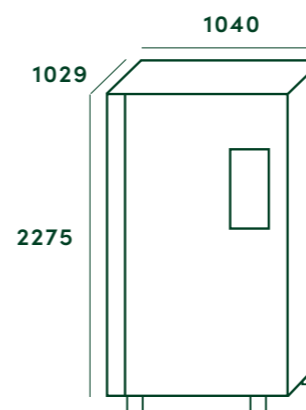
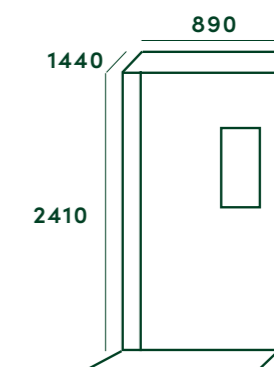

### CT 20-C+80 | CT 20-C+110

<b>capacity</b>	1 oven trolley Convotherm 20.10 (Plus 3)
<b>output chilling</b>	80kg   110kg
<b>output freezing</b>	65kg   95kg
<b>dimensions</b>	1040x1029x2275 mm
<b>voltage</b>	400V / 3N / 50 Hz
<b>construction</b>	monocoque version

## CHILLTOUCH ROLL-IN

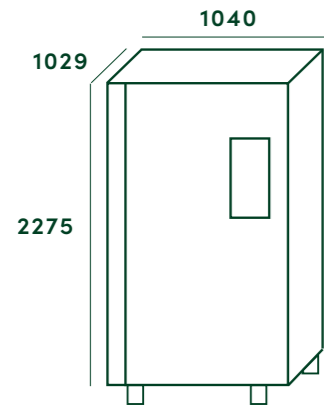

CT 20-R 80   CT 20-R 110	
capacity	1 oven trolley Rational 201 (SCC)
output chilling	80kg   110kg
output freezing	65kg   95kg
dimensions	1040x1029x2275 mm
voltage	400V / 3N / 50 Hz
construction	monocoque version

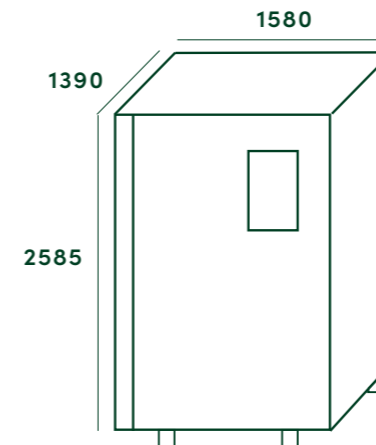

CT 40-C+/150   CT 40-C+/200	
capacity	1 oven trolley Convotherm 20.20 (Plus 3)
output chilling	150kg   200kg
output freezing	135kg   175kg
dimensions	1580x1390x2585 mm
voltage	400V / 3N / 50 Hz
construction	disassembled panels version

CT 30-110   CT 30-140	
capacity	2 trolleys GN 1/1 or 600x400 1 trolley GN 2/1 or 600x1000
max dimensions trolley	870x940x1980 mm
output chilling	110/140kg
output freezing	95kg   125kg
dimensions	1415x1225x2360 mm
voltage	400V / 3N / 50 Hz
construction	disassembled panels version

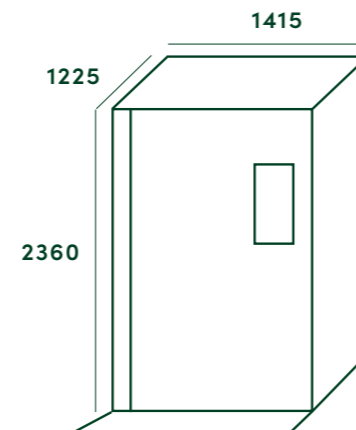

CT 40-R/150   CT 40-R/200	
capacity	1 oven trolley Rational 202 (SCC)
output chilling	150kg   200kg
output freezing	135kg   175kg
dimensions	1580x1390x2585 mm
voltage	400V / 3N / 50 Hz
construction	disassembled panels version

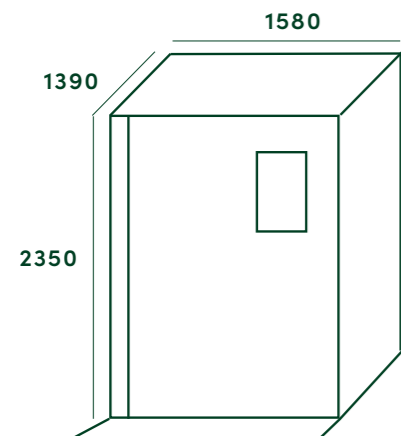
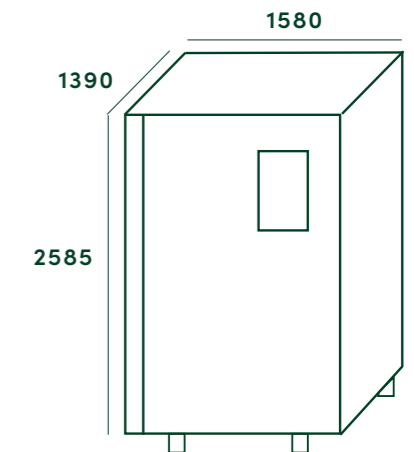

CT 40-150   CT 40-200	
capacity	2 trolleys GN 1/1 or 600x400 1 trolley GN 2/1 or 600x1000
max dimensions trolley	940x1100x1980 mm
output chilling	150kg   200kg
output freezing	135kg   175kg
dimensions	1580x1390x2350 mm
voltage	400V / 3N / 50 Hz
construction	disassembled panels version

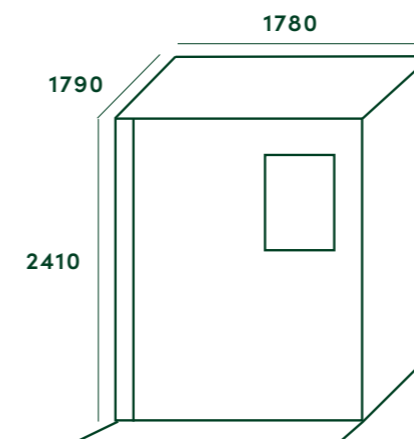

CT 50-270   CT 50-400	
capacity	2 trolleys GN 2/1 or 800x600 2 trolleys GN 2/1 or 600x1000
max dimensions trolley	1400x940x1980 mm
output chilling	270kg   390kg
output freezing	250kg   365 kg
dimensions	1780x1790x2410 mm
voltage	400V / 3N / 50 Hz
construction	disassembled panels version

# EASYCHILL MT

## TUNNEL BLAST CHILLER FOR BIGGER PRODUCTIONS

Easy Chill MT series is the proper solution for temperature management in big frozen production activities, industrial bakeries, ice-cream production companies, cooking centres and in food industry, generally. The MT Tunnel for roll-in trolleys can be customized and built following any layout or production needs, granting in every single context the maximum efficiency and functionality, always respecting the products.



EASYCHILL MT

# THE GIANTS OF COLD



□ WIDE DIMENSIONS

□ HIGH SPEED AIR FLOW

□ INTUITIVE INTERFACE

□ SEMI-HERMETIC REMOTE CONDENSING UNIT

□ PRODUCTION FLOW OPTIMIZATION, WITH ENTRY AND EXIT ON OPPOSITE SIDES

□ MODULAR EVAPORATORS BATTERIES

□ EASY MAINTENANCE, WITH INSPECTION DOOR

□ 100 MM WALLS THICKNESS, FOR AN OPTIMAL INSULATION

## CHILLING

Two different blast chilling cycles, both to chill down the products from +95°C down to +3°C at the core, in one hour and half.

Soft cycle is set for more delicate food or preparations, while Hard cycle must be used for more dense food and large products size. Each chilling cycle ends with automatic product conservation at +2°C inside the chamber.

## FREEZING

Thanks to the high machine efficiency and power, each freezing need will be satisfied. One only cycle to freeze products up to -18°C at the core, effective for dense, fat and big size food. At the end of each cycle, the automatic product conservation is set at -25°C inside the chamber.

## EASYCHILL MT

### MT2

capacity	2 (800x850 mm) 4 (450x650 mm)
output chilling	400kg
output freezing	370kg
internal dimensions	980 x 1630 x 2080 mm
external dimensions	2230 x 1830 x 2630 mm
voltage	400V / 3N / 50 Hz

### MT2 1/2

capacity	2 (800x850 mm) 4 (450x650 mm)
output chilling	400kg
output freezing	370kg
internal dimensions	980 x 2030 x 2080 mm
external dimensions	2230 x 2230 x 2630 mm
voltage	400V / 3N / 50 Hz

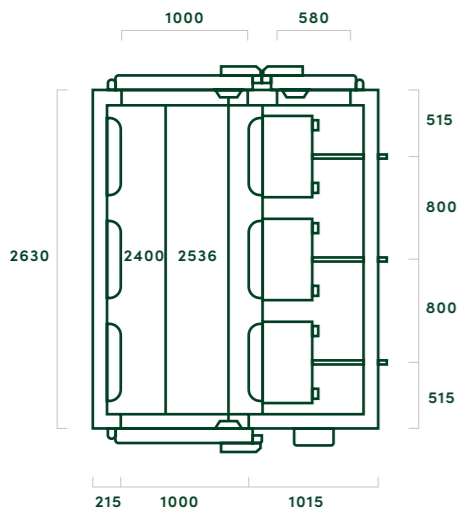
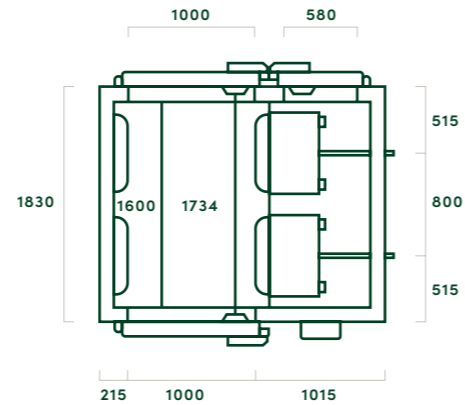

### MT3

capacity	3 (800x850 mm) 6 (450x650 mm)
output chilling	610kg
output freezing	560kg
internal dimensions	980 x 2430 x 2080 mm
external dimensions	2230 x 2630 x 2630 mm
voltage	400V / 3N / 50 Hz

### MT3 1/2

capacity	3 (800x850 mm) 8 (450x650 mm)
output chilling	610kg
output freezing	560kg
internal dimensions	980 x 2830 x 2080 mm
external dimensions	2230 x 3030 x 2630 mm
voltage	400V / 3N / 50 Hz

## EASYCHILL MT

### MT4

capacity	4 (800x850 mm) 8 (450x650 mm)
output chilling	810kg
output freezing	740kg
internal dimensions	980 x 3230 x 2080 mm
external dimensions	2230 x 3430 x 2630 mm
voltage	400V / 3N / 50 Hz

### MT4 1/2

capacity	2 (800x850 mm) 4 (450x650 mm)
output chilling	810kg
output freezing	740kg
internal dimensions	980 x 3630 x 2080 mm
external dimensions	2230 x 3830 x 2630 mm
voltage	400V / 3N / 50 Hz

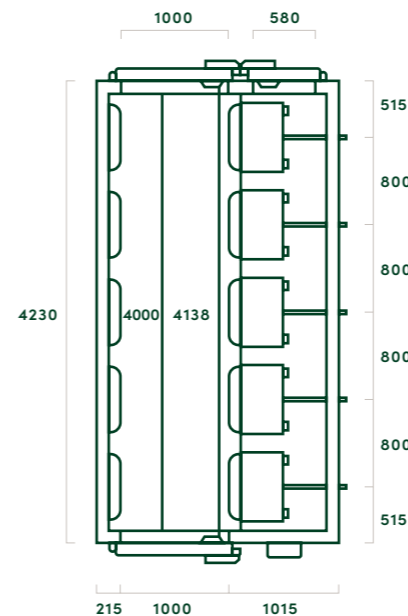
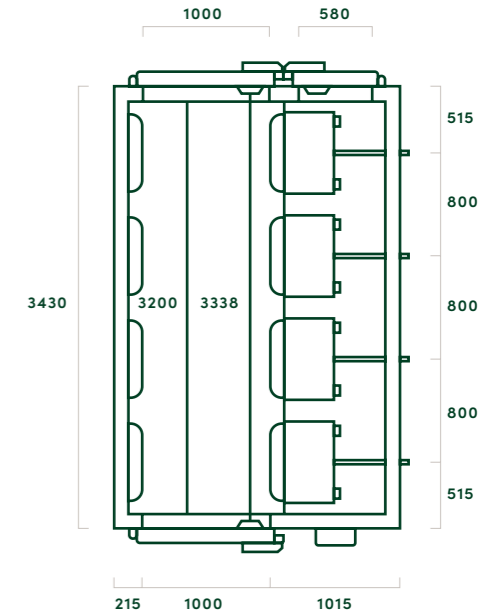

### MT5

capacity	5 (800x850 mm) 12 (450x650 mm)
output chilling	1000kg
output freezing	930kg
internal dimensions	980 x 4030 x 2080 mm
external dimensions	2230 x 4230 x 2630 mm
voltage	400V / 3N / 50 Hz

### MT5 1/2

capacity	5 (800x850 mm) 12 (450x650 mm)
output chilling	1000kg
output freezing	930kg
internal dimensions	980 x 4430 x 2080 mm
external dimensions	2230 x 4630 x 2630 mm
voltage	400V / 3N / 50 Hz

## EASYCHILL MT

### MT6

capacity	6 (800x850 mm)
	14 (450x650 mm)
output chilling	1230kg
output freezing	1120kg
internal dimensions	980 x 4830 x 2080 mm
external dimensions	2230 x 5030 x 2630 mm
voltage	400V / 3N / 50 Hz

### MT6 1/2

capacity	6 (800x850 mm)
	14 (450x650 mm)
output chilling	1230kg
output freezing	1120kg
internal dimensions	980 x 5230 x 2080 mm
external dimensions	2230 x 5430 x 2630 mm
voltage	400V / 3N / 50 Hz

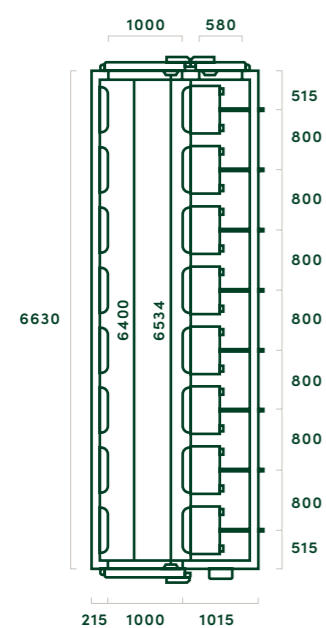
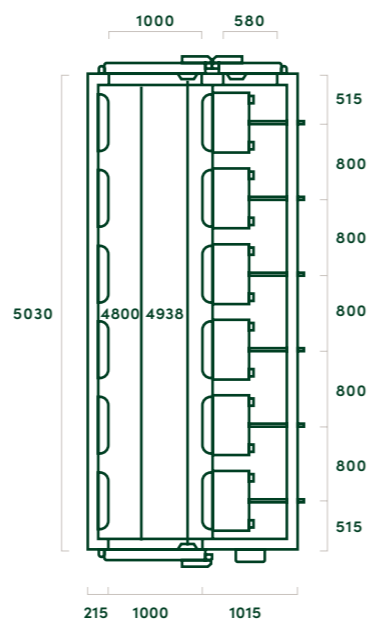

### MT8

capacity	8 (800x850 mm)
	18 (450x650 mm)
output chilling	1640kg
output freezing	1490kg
internal dimensions	980 x 6430 x 2080 mm
external dimensions	2230 x 6630 x 2630 mm
voltage	400V / 3N / 50 Hz

### MT8 1/2

capacity	8 (800x850 mm)
	20 (450x650 mm)
output chilling	1640kg
output freezing	1490kg
internal dimensions	980 x 6830 x 2080 mm
external dimensions	2230 x 7030 x 2630 mm
voltage	400V / 3N / 50 Hz

## EASYCHILL MT



Tecnomac, Castel MAC Srl  
Via del lavoro, 9  
31033 Castelfranco Veneto (TV) Italy  
Tel. +39 0423 738452  
E-mail: [tecnomac@castelmac.it](mailto:tecnomac@castelmac.it)  
**tecnomac.eu**



an Ali Group Company



The Spirit of Excellence